

Machine tap with right-hand spiral flutes 45°

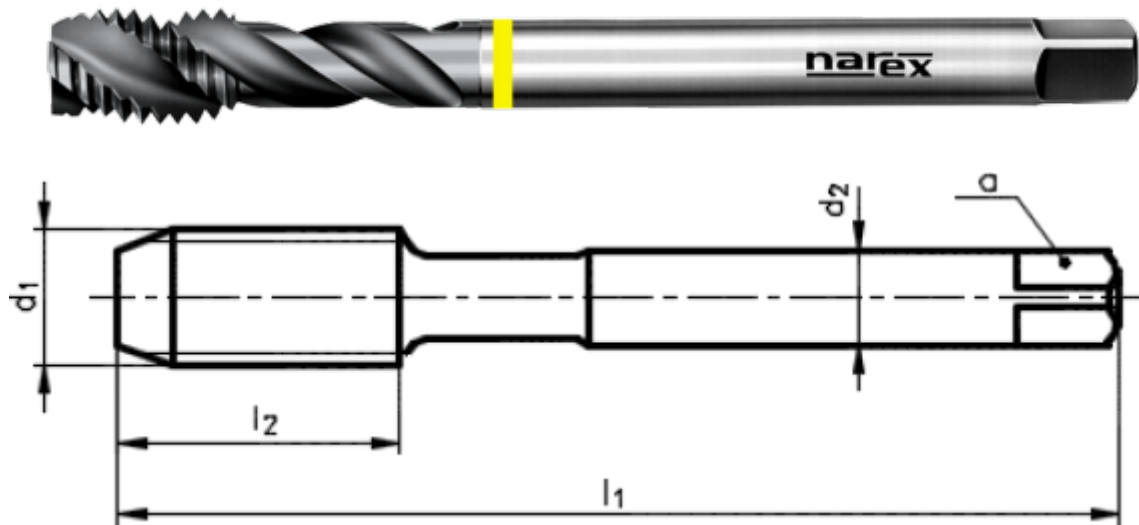

CATALOGUE NUMBER: 4720

Machine tap with spiral flute, metric, DIN 376, AluSpeed coated, suitable for unalloyed aluminium



THREAD M
ISO Metric coarse thread

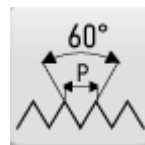

PROFILE SKETCH
60°



THREAD STANDARD
DIN13



TYPE AL
Tap for unalloyed aluminium



TAP MATERIAL
Super high speed steel



COATING
AluSpeed



TAP STANDARD
DIN 376



THREAD TOLERANCE
ISO 2 - 6H

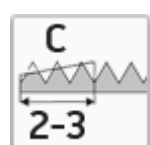

CHAMFER C
Length 2-3 pitch



SPIRAL FLUTE ANGLE
45°

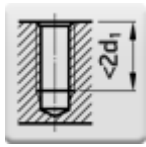

HOLE TYPE

Blind hole (thread length $< 2 d_1$)

Select product model

ID	D1	P	Tolerance	I1	I2	d2	a	Price excl. VAT	Price incl. VAT
041536360030000	M3	0,5	6H	56	5	2,2		15.30 EUR	18.51 EUR
041536360040000	M4	0,7	6H	63	7	2,8	2,1	15.45 EUR	18.69 EUR
041536360050000	M5	0,8	6H	70	8	3,5	2,7	15.80 EUR	19.12 EUR
041536360060000	M6	1	6H	80	10	4,5	3,4	15.80 EUR	19.12 EUR
041536360080000	M8	1,25	6H	90	13	6	4,9	17.65 EUR	21.36 EUR
041536360100000	M10	1,5	6H	100	15	7	5,5	21.90 EUR	26.50 EUR
041536360120000	M12	1,75	6H	110	18	9	7	25.40 EUR	30.73 EUR
041536360140000	M14	2	6H	110	20	11	9	31.70 EUR	38.36 EUR
041536360160000	M16	2	6H	110	20	12	9	35.10 EUR	42.47 EUR
041536360180000	M18	2,5	6H	125	25	14	11	50.70 EUR	61.35 EUR
041536360200000	M20	2,5	6H	140	25	16	12	52.10 EUR	63.04 EUR

Use

MACHINED MATERIAL	HOLE TYPE	CUTTING SPEED	LUBRICATION	USE
Unalloyed aluminium	blind hole (thread length $< 1,5 d_1$, pilot drilling depth $\geq L+d_1$)	15-35	Cutting Oil/Emulsion	Recommended use
Unalloyed aluminium	blind hole (thread length $L < 2xd_1$)	15-35	Cutting Oil/Emulsion	Recommended use
Unalloyed aluminium	blind hole (thread length $L < 1,5xd_1$)	15-35	Cutting Oil/Emulsion	Recommended use

NAREX Ždánice, spol. s r.o.

Městečko 250
696 32 Ždánice, Česká republika

Tel.: +420 518 607 111
Fax: +420 518 607 153
E-mail: sales@narexzd.cz
Web: www.narexzd.cz