

# Machine tap with right-hand spiral flutes 40°

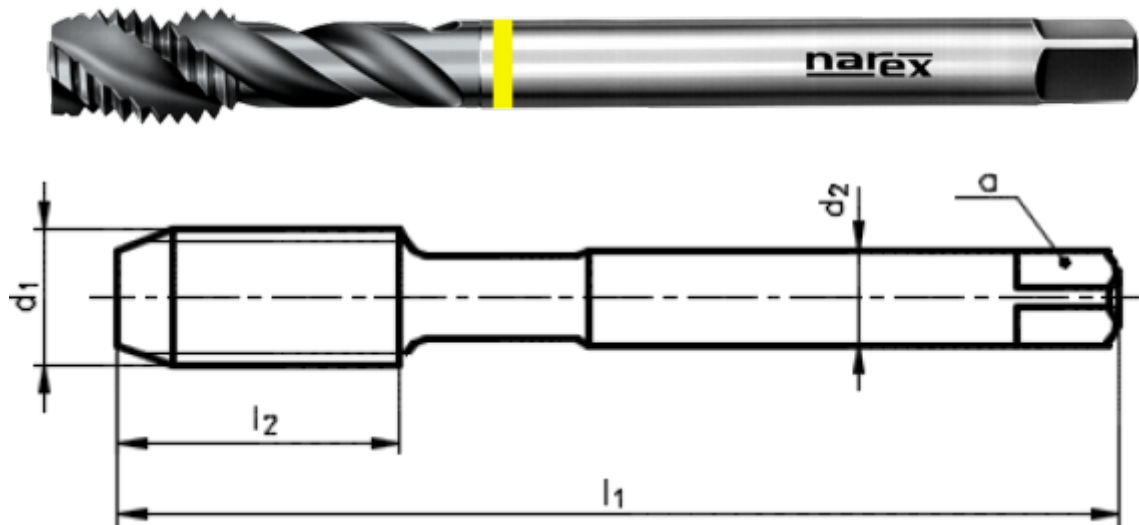

**CATALOGUE NUMBER: 4670**

Machine tap with spiral flute, metric, DIN 376, AluSpeed coating, suitable for aluminium alloys with Si>10 %



**THREAD M**  
ISO Metric coarse thread

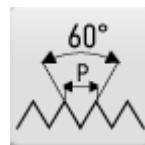

**PROFILE SKETCH**  
60°



**THREAD STANDARD**  
DIN13



**TYPE AL**  
Tap for unalloyed aluminium



**TAP MATERIAL**  
Super high speed steel



**COATING**  
AluSpeed

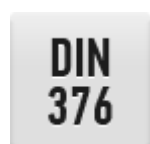

**TAP STANDARD**  
DIN 376



**THREAD TOLERANCE**  
ISO 2 - 6H

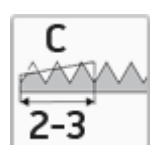

**CHAMFER C**  
Length 2-3 pitch



**SPIRAL FLUTE ANGLE**  
40°

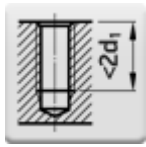

#### HOLE TYPE

Blind hole (thread length  $< 2 d1$ )

## Select product model

ID	D1	P	Tolerance	I1	I2	d2	a	Price excl. VAT	Price incl. VAT
041536336030000	M3	0,5	6H	56	5	2,2		21.05 EUR	25.47 EUR
041536336040000	M4	0,7	6H	63	7	2,8	2,1	21.45 EUR	25.95 EUR
041536336050000	M5	0,8	6H	70	8	3,5	2,7	22.30 EUR	26.98 EUR
041536336060000	M6	1	6H	80	10	4,5	3,4	22.30 EUR	26.98 EUR
041536336080000	M8	1,25	6H	90	13	6	4,9	24.60 EUR	29.77 EUR
041536336100000	M10	1,5	6H	100	15	7	5,5	30.60 EUR	37.03 EUR
041536336120000	M12	1,75	6H	110	18	9	7	35.70 EUR	43.20 EUR
041536336140000	M14	2	6H	110	20	11	9	44.45 EUR	53.78 EUR
041536336160000	M16	2	6H	110	20	12	9	49.05 EUR	59.35 EUR
041536336180000	M18	2,5	6H	152	25	14	11	70.40 EUR	85.18 EUR
041536336200000	M20	2,5	6H	140	25	16	12	72.85 EUR	88.15 EUR

## Use

MACHINED MATERIAL	HOLE TYPE	CUTTING SPEED	LUBRICATION	USE
Aluminium alloys si content $> 10\%$	blind hole (thread length $L < 1,5 \times d1$ )	12-20	Emulsion	Recommended use
Aluminium alloys si content $> 10\%$	blind hole (thread length $L < 2 \times d1$ )	12-20	Emulsion	Recommended use
Aluminium alloys si content $> 10\%$	blind hole (thread length $L < 2,5 \times d1$ )	12-20	Emulsion	Recommended use

<b>MACHINED MATERIAL</b>	<b>HOLE TYPE</b>	<b>CUTTING SPEED</b>	<b>LUBRICATION</b>	<b>USE</b>
Aluminium alloys si content > 10%	blind hole (thread length < 1,5 d1, pilot drilling depth $\geq L+d1$ )	12-20	Emulsion	Recommended use

**NAREX Ždánice, spol. s r.o.**

Městečko 250  
696 32 Ždánice, Česká republika

Tel.: +420 518 607 111  
Fax: +420 518 607 153  
E-mail: [sales@narexzd.cz](mailto:sales@narexzd.cz)  
Web: [www.narexzd.cz](http://www.narexzd.cz)